

# Three-Membered Cyclic Fluoronium Ions in Gaseous Ion-Neutral Complexes

Viet Nguyen, Xueheng Cheng, and Thomas Hellman Morton\*

Contribution from the Department of Chemistry, University of California, Riverside, California 92521-0403. Received September 30, 1991.  
Revised Manuscript Received February 25, 1992

**Abstract:** The fluoriranium ion ( $\text{CH}_2\text{CH}_2\text{F}^+$ , **1a**) is shown to exist as an intermediate within ion-neutral complexes derived from the molecular ions of  $\beta$ -fluorophenetole ( $\mathbf{8}^{+\bullet}$ ). Ion-neutral complexes containing the isomeric ion  $\text{CH}_3\text{CHF}^+$  (**2a**) also occur. The parent neutral **8** favors the gauche conformation, and theoretical calculations show that the radical cation  $\mathbf{8}^{+\bullet}$  and the conjugate acid ions should also favor their gauche conformers. NMR analysis of the neutral fluoroethylenes from deuterated analogues of  $\mathbf{8}^{+\bullet}$  show that fluorine bridging to form **1a** and hydride shift to form **2a** take place competitively and not sequentially. Nearly the same ratios of  $\text{C}_2\text{H}_2\text{DF}$  loss to  $\text{C}_2\text{HD}_2\text{F}$  loss are observed for the radical cations and from the  $\text{MD}^+$  conjugate acid ions. By contrast, free  $\text{C}_2\text{H}_2\text{D}_2\text{F}^+$  ions quenched by chloride abstraction from  $(\text{CH}_3)_3\text{CCl}$  have the structure **2a**, in which sequential transpositions have occurred. The difference between free ions and ions within complexes is ascribed to the millionfold difference in lifetimes under the experimental conditions.

Cyclic halonium ions have a long history as intermediates in organic chemistry. Bridged structures are well-known for other halogens, but the case of X = fluorine has heretofore proven elusive. When X = chlorine or bromine, the energetics of isomerization via hydride shift to form  $\alpha$ -haloethyl cations, drawn in eq 1, are delicately balanced. Ions **1b** and **2b** (X = Cl) have nearly

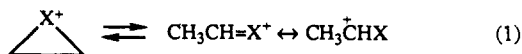

<b>1a</b> X = F	<b>2a</b> X = F
<b>1b</b> X = Cl	<b>2b</b> X = Cl
<b>1c</b> X = Br	<b>2c</b> X = Br

the same heats of formation, but only **2b** is observed by low-temperature matrix isolation.<sup>1</sup> Ions **1c** and **2c** (X = Br) are also close in energy, but only **1c** is observed under the same conditions. For X = F, ab initio<sup>2</sup> and empirical estimates<sup>3,4</sup> place **2a**, which is a stable ion in the gas phase,<sup>5</sup> 70 kJ mol<sup>-1</sup> (17 kcal mol<sup>-1</sup>) lower than **1a**, and the latter has never been observed directly.

We describe here a reaction that produces **1a** and **2a** competitively in the gas phase under conditions where the interconversion depicted in eq 1 does not take place. Previous efforts to produce **1a**<sup>6</sup> or its higher homologues<sup>4,7</sup> show products in which fluorine transposes (consistent with the intermediacy of epifluoronium ions), but the species that have been detected are the products of subsequent rearrangement. For instance, the mass spectrometric evidence that a free fluoroethyl cation might pass through **1a** hinges upon its expulsion of a methyl radical,<sup>6</sup> which means that the ion observed to decompose must have been **2a**. This raises the question as to whether cyclic fluoronium ions are stable structures or transition states.

The same question is raised by studies of fluorine transposition within positive ions in ion-neutral complexes. Electron impact on alkyl phenyl ethers generates complexes in which the alkyl

moiety undergoes rearrangements as though it were a free cation that lives for a very short time. When the starting neutral is a 1-phenoxyalkane, cleavage of the C-O bond would have generated a primary cation. Therefore, complexes are formed that contain a rearranged alkyl cation and a phenoxy radical. Typically, simple rearrangements occur (such as hydride or alkyl shifts). Deep-seated isomerizations (e.g. *s*-Bu  $\rightarrow$  *t*-Bu, cyclohexyl  $\rightarrow$  1-methylcyclopentyl, or  $\text{CH}_3\text{CH}_2\text{CHF} \rightarrow (\text{CH}_3)_2\text{CF}^+$ ) tend not to be observed, owing to the brief lifetimes (estimated on the order of 1 ns) of ion-neutral complexes.<sup>8</sup>

When monofluoroalkyl phenyl ethers are ionized, complexes are formed that contain fluoroalkyl cations. The electron bombardment flow (EBFlow) reactor allows us to collect the neutral products that result from the unimolecular decomposition of the complexes at pressures on the order of  $10^{-4}$  Torr and to analyze them using NMR spectroscopy.<sup>8c</sup> As eq 2 depicts, previous studies

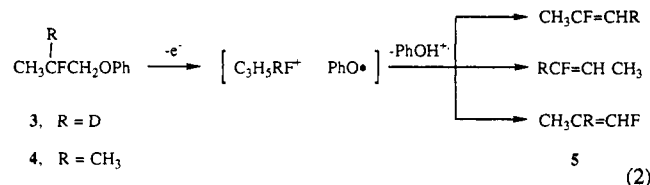

have shown neutral products (e.g. **5**) that provide evidence for fluoride shift. Isotopic labeling of neutral starting materials **3** and **4** shows that the transposition (which occurs competitively with methyl or hydride shift) does *not* occur via elimination of HF (to form an allylic cation) followed by readdition.<sup>4,7</sup> Furthermore, the distribution of <sup>13</sup>C from labeled **3** informs us that the intermediate  $\text{C}_3\text{H}_5\text{DF}^+$  does experience reversible hydrogen shifts but does not have time to undergo a deep-seated rearrangement to its most stable isomer (even though free fluoropropyl cations do so extensively on the 1-ms time scale).

The experiments summarized by eq 2 warrant the inference that fluorine is capable of transposing via three-membered cyclic fluoronium ions **6**. The available data do not tell us whether such a structure is an intermediate or a transition state or whether it intervenes when alternative mechanisms are possible. For example, transposition in the intermediate derived from **3** might have occurred via a structure such as **7**, which can be viewed as being

(1) Vancik, H.; Percac, K.; Sunko, D. E. *J. Chem. Soc., Chem. Commun.* **1991**, 807-809.

(2) (a) Hehre, W. J.; Hiberty, P. C. *J. Am. Chem. Soc.* **1974**, *96*, 2665-2677. (b) Cremer, D.; Kraka, E. *J. Am. Chem. Soc.* **1985**, *107*, 3800-3810.

(3) Stams, D. A.; Thomas, T. D.; MacLaren, D. C.; Ji, D.; Morton, T. H. *J. Am. Chem. Soc.* **1990**, *112*, 1427-1434.

(4) Shaler, T. A.; Morton, T. H. *J. Am. Chem. Soc.* **1991**, *113*, 6771-6779.

(5) Ridge, D. P. *J. Am. Chem. Soc.* **1975**, *97*, 5670-5674.

(6) Ciommer, B.; Schwarz, H. *Z. Naturforsch.* **1983**, *38B*, 635-638.

(7) Shaler, T. A.; Morton, T. H. *J. Am. Chem. Soc.* **1989**, *111*, 6868-6870; **1990**, *112*, 4090.

(8) (a) Morton, T. H. *Tetrahedron* **1982**, *38*, 3195-3243. (b) Morton, T. H.; Chronister, E. L. *J. Am. Chem. Soc.* **1990**, *112*, 133-139. (c) Morton, T. H. *Org. Mass Spectrom.* **1991**, *26*, 18-23. (d) Morton, T. H. *Org. Mass Spectrom.* **1992**, *27*, 353-368. (e) Morton, T. H. In *Techniques for the Study of Ion-Molecule Reactions*; Farrar, J. M., Saunders, W. H., Jr., Eds.; Techniques of Chemistry XX; Wiley-Interscience: New York, 1988; pp 119-164.

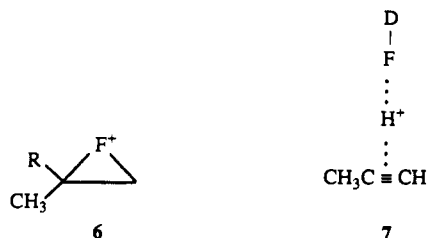

isoelectronic with a van der Waals complex of water with propyne.<sup>4</sup> While this kind of structure (which would transpose hydrogen at the same time as fluorine) cannot be definitively ruled out for 3, such a structure is not possible for 4.

This paper presents a comparison of the behavior of free fluoroethyl cations in the gas phase with the behavior of those that are formed in ion-neutral complexes. Our study answers two questions about fluorine transposition in a fluoroethyl cation, the simplest system in which fluorine can bridge. The first is whether fluorine transposes with concomitant transposition of hydrogen (e.g. via structures such as 7). The answer to this question is negative. The second is whether the bridged ion corresponds to a discrete intermediate. Here we conclude that the answer is affirmative.

### Experimental Section

The EBFlow technique has been described in detail elsewhere.<sup>4,7-9</sup> In brief, gaseous substrates (in the pressure range  $10^{-4}$ – $10^{-3}$  Torr) are subjected to bombardment by 70-eV electrons (currents on the order of  $10^{-5}$ – $10^{-4}$  A) while flowing from a sample bulb into a liquid-nitrogen-cooled trap. The reaction vessel is housed in a solenoid electromagnet (flux density on the order of 0.2 T), which focuses the electron beam on an axis and helps keep ions from striking the walls. Electrically charged species exit the reaction vessel into a separate, differentially pumped chamber, where the products from their neutralization are removed and do not contaminate the neutral products recovered from the reaction vessel. Recovered neutral product mixtures were analyzed by 470.4-MHz <sup>19</sup>F NMR spectroscopy on a General Electric GN500 instrument. The isotopomers of fluoroethylene were identified by their <sup>19</sup>F–<sup>2</sup>H spin-spin couplings.

Mass spectra were recorded on a VG ZAB 2F (B-E), on a VG 7070 (E-B), and on an HP 5989A quadrupole on-line with a HP 5990 gas chromatograph. Chemical ionization mass spectra were performed by introducing deuterium gas (Cambridge Isotope Laboratories) into the ZAB source. Ab initio calculations were performed using the SPARTAN software on a Silicon Graphics 4D/35 Personal Iris Computer.<sup>10</sup> NMR proton-proton spin-spin splitting patterns were simulated using the LAOCOON program.<sup>11</sup>

**Materials.** Unless otherwise specified, starting materials were used as received from commercial suppliers without further purification. Deuterated 2-bromo-1-fluoroethane was prepared by reaction of BrC<sub>2</sub>H<sub>4</sub>OH (from reduction of methyl bromoacetate with LiAlD<sub>4</sub>) with (diethylamino)sulfur trifluoride (DAST) and consisted of a 92/8 mixture BrCH<sub>2</sub>CH<sub>2</sub>F and BrCD<sub>2</sub>CH<sub>2</sub>F.

**2-Fluoroethyl Phenyl Ethers (8).** 2-Phenoxyethanol (prepared by LiAlH<sub>4</sub> reduction of phenoxyacetic acid) was converted to 2-phenoxy-1-fluoroethane (**8a**) by reaction with DAST in CH<sub>2</sub>Cl<sub>2</sub>. After distillation under reduced pressure, the product was recrystallized from acetone; mp 37–39°. IR (KBr pellet): 3077, 3064, 3046, 2998, 2963, 2935, 2925, 2889, 2873, 1955, 1865, 1603, 1588, 1494, 1448, 1373, 1299, 1283, 1250, 1236, 1177, 1156, 1110, 1087, 1069, 1046, 1025, 971, 923, 895, 880, 825, 792, 759, 695, 603, 517, 470 cm<sup>-1</sup>. Raman (solid, 514-nm exciting line): 3075, 3069, 3061, 3014, 2992, 2958, 2921, 2886, 2868, 2798, 2734, 1593, 1583, 1448, 1294, 1232, 1159, 1109, 1068, 1047, 995, 922, 882, 830, 792, 771, 758, 614, 517, 472, 426, 303, 251, 188 cm<sup>-1</sup>. <sup>1</sup>H NMR (300 MHz, CDCl<sub>3</sub>): δ 4.22 (doublet of AA'XX', J<sub>HF</sub> = 29 Hz, <sup>2</sup>J = –9.9 Hz, <sup>3</sup>J = 2.1, 5.9 Hz), 4.73 (doublet of AA'XX', J<sub>HF</sub> = 47 Hz, <sup>2</sup>J = –11.0 Hz, <sup>3</sup>J = 2.1, 5.9 Hz). 2-Phenoxy-1,1-dideuterio-1-fluoroethane (**8b**) was prepared by reacting the corresponding alcohol (from reduction of phen-

oxyacetic acid with LiAlD<sub>4</sub>) with DAST. IR (KBr pellet): 3079, 3062, 3042, 2937, 2922, 2869, 2259, 2158, 1973, 1955, 1865, 1603, 1588, 1494, 1458, 1448, 1390, 1308, 1298, 1254, 1184, 1165, 1155, 1106, 1084, 1058, 1030, 951, 895, 880, 846, 759, 696, 584, 519, 459, 417 cm<sup>-1</sup>. Raman (solid, 514-nm exciting line): 3076, 3069, 3061, 2934, 2919, 2866, 2752, 2256, 2214, 2156, 2127, 2113, 1596, 1584, 1491, 1448, 1396, 1294, 1281, 1244, 1236, 1182, 1170, 1159, 1106, 1087, 1056, 1026, 995, 952, 918, 895, 879, 846, 829, 771, 758, 735, 698, 615, 584, 518, 462, 419, 280, 252, 177 cm<sup>-1</sup>. <sup>1</sup>H NMR (300 MHz, CDCl<sub>3</sub>): δ 4.21 (doublet, J<sub>HF</sub> = 27.7 Hz, 2 H), 6.89–7.01 (multiplet, 3 H), 7.25–7.34 (multiplet, 2 H). <sup>19</sup>F NMR (282 MHz, CDCl<sub>3</sub>): –220 ppm (quintet, J<sub>DF</sub> = 22.3 Hz, of triplets, J<sub>HF</sub> = 7.2 Hz). Bromoacetic-d<sub>2</sub> acid was prepared by reaction of CD<sub>3</sub>COOH with Br<sub>2</sub> and PBr<sub>3</sub>, converted to phenoxyacetic-d<sub>2</sub> acid by reaction with anhydrous phenol,<sup>4</sup> reduced with LiAlH<sub>4</sub>, and converted to 2-phenoxy-2,2-dideuterio-1-fluoroethane (**8c**) by reaction with DAST. IR (KBr pellet): 3079, 3062, 3048, 2996, 2962, 2887, 2372, 2355, 2337, 2328, 2232, 2206, 2112, 1955, 1865, 1603, 1586, 1493, 1453, 1391, 1295, 1258, 1197, 1178, 1155, 1117, 1095, 1020, 999, 979, 888, 783, 766, 756, 695, 589, 518, 438 cm<sup>-1</sup>. Raman (solid, 514-nm exciting line): 3075, 3068, 3061, 2992, 2957, 2882, 2754, 2228, 2204, 2151, 2110, 1591, 1583, 1452, 1390, 1293, 1266, 1245, 1240, 1182, 1159, 1113, 1085, 1027, 1019, 998, 979, 887, 831, 784, 760, 614, 590, 517, 441, 416, 285, 248, 184 cm<sup>-1</sup>. <sup>1</sup>H NMR (300 MHz, CDCl<sub>3</sub>): δ 4.76 (doublet, J<sub>HF</sub> = 47.4 Hz, 2 H), 6.92–7.01 (multiplet, 3 H), 7.28–7.33 (multiplet, 2 H). <sup>19</sup>F NMR (282 MHz, CDCl<sub>3</sub>): –223 ppm (triplet, J<sub>HF</sub> = 47.7 Hz, of quintets, J<sub>DF</sub> = 4.6 Hz).

### Results

One of the hallmarks of ion-neutral complexes formed from ionized alkyl phenyl ethers is the parallelism between alkene loss from radical cations (odd-electron ions) and alkene loss from conjugate acid ions (even-electron cations). This was first reported in 1976 by Benoit and Harrison, who observed that expulsion of isotopically labeled propenes from various deuterated *n*-propyl phenyl ethers follows nearly the same pattern under conditions of electron impact (which forms radical cations) and chemical ionization (which forms the conjugate acid ions).<sup>12</sup> This similarity is readily explained by a complex-mediated mechanism, since the rearrangements of cations within complexes should not depend upon the identity of the leaving group, and the distribution of deuterium in the products should depend only on its proton affinity.

The congruence of electron impact (EI) and chemical ionization (CI) results is hard to explain without invoking intermediate complexes. Results from the literature<sup>12</sup> for *n*-propyl phenyl ethers (X = CH<sub>3</sub>) are summarized in eq 3, which shows complete

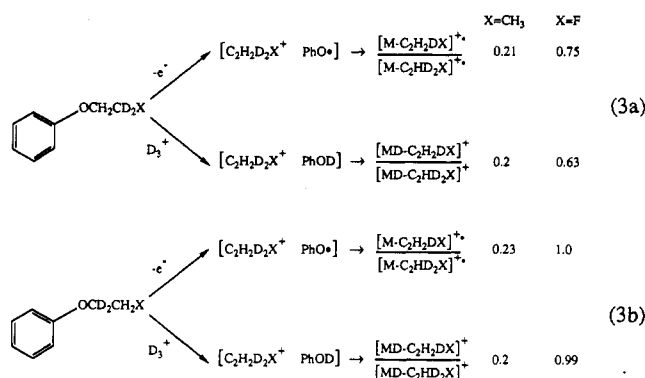

unimolecular scrambling of all the alkyl hydrogens. (The results for D<sub>3</sub><sup>+</sup> chemical ionization have not been reported; the approximate ion ratios are interpolated from the reported data for chemical ionization using H<sub>2</sub>,<sup>12</sup> CH<sub>4</sub>,<sup>12,13</sup> and CD<sub>4</sub><sup>13</sup> reagent gases.) It is worth noting that the same results for the radical cation decompositions have been observed on the shortest time scales (10<sup>-11</sup> s) measurable by field ionization kinetics.<sup>14</sup> This implies

(9) (a) Redman, E. W.; Johri, K. K.; Lee, R. W. K.; Morton, T. H. *J. Am. Chem. Soc.* **1984**, *106*, 4639–4640 and references therein. (b) Redman, E. W.; Johri, K. K.; Morton, T. H. *J. Am. Chem. Soc.* **1985**, *107*, 780–784. (c) Stams, D. A.; Johri, K. K.; Morton, T. H. *J. Am. Chem. Soc.* **1988**, *110*, 699–706.

(10) SPARTAN; Wavefunction Inc.: Irvine, CA.

(11) Bothner-By, A.; Castellano, S. M. LAOCN3. In *Computer Programs for Chemistry*; Detar, D. F., Ed.; Benjamin: Reading, MA, 1962; Vol. 1.

(12) Benoit, F. M.; Harrison, A. G. *Org. Mass Spectrom.* **1976**, *11*, 599–608.

(13) (a) Morton, T. H.; Kondrat, R. W. *Org. Mass Spectrom.* **1991**, *26*, 410–415. (b) Morton, T. H.; Kondrat, R. W. *Org. Mass Spectrom.* **1991**, *56*, 952–957. In the last two paragraphs on p 954, C<sub>6</sub>H<sub>6</sub>D<sup>+</sup> should read C<sub>6</sub>H<sub>6</sub>DO<sup>+</sup> and C<sub>6</sub>H<sub>6</sub>O<sup>+</sup> should read C<sub>6</sub>H<sub>7</sub>O<sup>+</sup>.

(14) Borchers, F.; Levens, K.; Beckey, H. D. *Int. J. Mass Spectrom. Ion Phys.* **1976**, *21*, 125–132.

that ion-neutral complexes can form very promptly after ionization.

The 2-fluoroethyl phenyl ethers ( $X = F$ , **8**) also exhibit a striking similarity in their electron impact (EI) and chemical ionization (CI) mass spectra. The undeuterated compound (**8a**) gives a 70-eV electron impact spectrum in which  $\text{PhOH}^{+\bullet}$  ( $[\text{M} - \text{CH}_2 = \text{CHF}]^{+\bullet}$ ) constitutes the base peak, approximately 30% of the total ionization. The principal fragment ions in the  $\text{D}_3^+$  chemical ionization mass spectrum are  $[\text{MD} - \text{CH}_2 = \text{CHF}]^+$  and  $[\text{MD} - \text{DF}]^+$  in a ratio of 100/80. (The  $\text{MD}^+$  ion intensity is sensitive to source pressure: reported fragment ion ratios correspond to spectra in which the intensity of that ion is less than or equal to one-fifth the intensity of the base peak.) While a small amount of exchange between  $\text{D}^+$  and the alkyl chain (0.09 times the base peak intensity) has been reported in the CI mass spectrum of *n*-propyl phenyl ether,<sup>12</sup> such exchange occurs to a much lesser extent ( $\leq 0.05$  times the base peak intensity) in **8a**. This is in keeping with expectation, as phenol has a proton affinity 90 kJ mol<sup>-1</sup> greater than that of the expelled fluoroethylene (while the difference between the proton affinities of phenol and propene is only 70 kJ mol<sup>-1</sup>).<sup>5,15</sup> Since the exchange between  $\text{D}^+$  and the alkyl chain has been shown to occur via reversible proton transfer within ion-neutral complexes,<sup>13</sup> it stands to reason that the contribution from the back-reaction will decrease as the exothermicity of proton transfer increases.

We observe the same proportions of  $\text{PhOH}^{+\bullet}$  and  $\text{PhOD}^{+\bullet}$  in the 70-eV electron impact mass spectra of  $\text{PhOCH}_2\text{CD}_2\text{F}$  (**8b**) and  $\text{PhOCD}_2\text{CH}_2\text{F}$  (**8c**) (allowing for minor variations from instrument to instrument), as previously reported by Nibbering and co-workers.<sup>16</sup> The ratios of  $\text{C}_2\text{H}_2\text{DF}$  loss to  $\text{C}_2\text{HD}_2\text{F}$  loss that we observe in the  $\text{D}_3^+$  CI spectra are compared with the published EI results in eq 3. The principal fragment ions from  $\text{D}_3^+$  CI mass spectroscopy of **8b** are  $[\text{MD} - \text{C}_2\text{HD}_2\text{F}]^+$ ,  $[\text{MD} - \text{C}_2\text{H}_2\text{DF}]^+$ , and  $[\text{MD} - \text{DF}]^+$  in a ratio (corrected for <sup>13</sup>C natural abundance) of  $m/z$  96:97:123 = 82/52/100. The same ions are seen from **8c** in a ratio of  $m/z$  96:97:123 = 65/65/100 (corrected for <sup>13</sup>C natural abundance).

We inquire as to whether the similarity of EI and CI spectra reflects an inherent similarity in the conformer distribution of the parent ions. Neutral **8** is expected to have two predominant conformers: an achiral one, in which the phenoxy and fluorine are anti, and a *d, l* pair, in which these functional groups are gauche. SCF calculations using the 3-21G basis set predict that the optimized geometry of the anti conformer lies  $\Delta H^\circ_{298}(\text{g}) = 8$  kJ mol<sup>-1</sup> above that of the gauche conformer but has an entropy that is  $\Delta S^\circ_{298} = 20$  J mol<sup>-1</sup> K<sup>-1</sup> greater. The calculated dihedral angles are summarized in Figure 1. The anti conformer approaches *C<sub>s</sub>* symmetry, even though no constraints were imposed in the optimization. Using the proton-proton spin-spin couplings reported for gauche 2-fluoroethanol in chloroform<sup>17</sup> ( $^2J_{\text{CH}_2\text{O}} = -12.0$  Hz,  $^2J_{\text{CH}_2\text{F}} = -9.1$  Hz,  $^3J + ^3J' = 8.4$  Hz,  $^3J - ^3J' = 3.5$  Hz) and the dihedral angles ( $\theta$ ) that we calculated for 2-fluoroethanol at 3-21G (summarized in Figure 1), the appropriate Karplus equations<sup>18</sup> for vicinal proton-proton splittings in **8** should be

$$^3J = 7.3 \cos^2 \theta + 0.3 \quad 0^\circ \leq \theta \leq 90^\circ \quad (4a)$$

$$^3J = 10.0 \cos^2 \theta + 0.3 \quad 90^\circ \leq \theta \leq 180^\circ \quad (4b)$$

While there are some differences between the optimized SCF geometries computed at 3-21G and 6-31G\* for 2-fluoroethanol (for instance, the OH...F distance is 2.42 Å with the latter basis

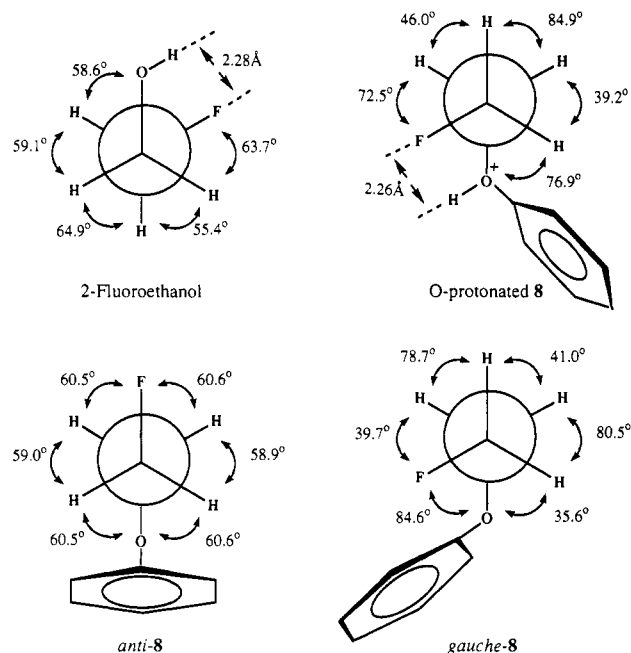

Figure 1. SCF-optimized geometries (3-21G) of 2-fluoroethanol, anti and gauche **8**, and one conformer of the conjugate acid of **8**.

set), the dihedral angles differ by less than 5%, and the coefficients for the  $\cos^2 \theta$  terms based on the 6-31G\* geometry (8.2 Hz for acute angles and 9.4 Hz for obtuse) do not differ greatly from those in eq 4.

Using the dihedral angles for **8** summarized in Figure 1, we calculate that the vicinal coupling constants for the anti conformer of **8a** ought to be  $^3J = 2.2$  and 10.3 Hz, while the vicinal coupling constants for a gauche conformer should be  $^3J = 6.8$  and 0.5 Hz. From the observed vicinal coupling constants, we have two independent determinations of the mole fraction of gauche: 0.804 and 0.836. The agreement between these two values ratifies our use of SCF-determined dihedral angles and confirms that the anti conformer is less stable than the gauche (experimental  $\Delta G^\circ = 2.5$  kJ mol<sup>-1</sup> in chloroform solution). This may be compared with the experimental preference for gauche reported in the case of 1,2-difluoroethane, for which higher level ab initio computations favor the anti conformation (SCF calculations with even small basis sets give an FCCF dihedral angle close to the value of 74° extracted from the microwave spectrum).<sup>19</sup>

The conjugate acid  $\text{MH}^+$  for  $\text{M} = \text{8}$  is calculated to have gauche conformers lower in energy than its anti conformers. Likewise, semiempirical calculations (AM1) predict that the radical cation  $\text{8}^{+\bullet}$  also favors the gauche conformers (as would be anticipated on the basis of the expectation that the C-F dipole will point toward the atom on which positive charge is localized). It is reasonable to suppose that if the partition among isomeric ion-neutral complexes depends upon the conformations of the parent ions, then the  $\text{M}^{+\bullet}$  and  $\text{MH}^+$  ions ought to give comparable branching ratios.

The EBFlow data argue that the epifluoronium ion (**1a**) is a bona fide intermediate within ion-neutral complexes. Ionization of  $\beta$ -fluoroethyl-*d*<sub>2</sub> phenyl ethers **8b** and **8c** in the gas phase yields the neutral products represented in eq 5. Cationized alkyl phenyl ethers decompose in the gas phase by a process that has been described as an analogue of solvolysis.<sup>4,7-9</sup> This is pictured by pathways i and ii in eq 5, which proceed via intermediate ion-neutral complexes.

Usually this mechanism predominates over the direct  $\beta$ -elimination represented by pathway iii. The final products from the ion-neutral complexes result from Brønsted acid-base reactions

(15) Lias, S. G.; Liebman, J. F.; Levin, R. D. *J. Phys. Chem. Ref. Data* **1984**, *13*, 695-808.

(16) (a) Theissling, C. B.; Nibbering, N. M. M. *Adv. Mass Spectrom.* **1978**, *7B*, 1287-1295. (b) Russell, D. H.; Gross, M. L.; van der Greef, J.; Nibbering, N. M. M. *Org. Mass Spectrom.* **1979**, *14*, 474-479. The first two entries in the top line of data in Table 2 have been transposed.

(17) Klaus, G. R.; Wessels, P. L. *J. Mol. Struct.* **1979**, *6*, 471-478.

(18) Jackman, L. M.; Sternhell, S. *Applications of Nuclear Magnetic Resonance Spectroscopy in Organic Chemistry*, 2nd ed.; Pergamon Press: New York, 1969.

(19) (a) Felder, P.; Guenthard, H. H. *Chem. Phys.* **1982**, *71*, 9-25. (b) Smits, G. F.; Krol, M. C.; Van Kampen, P. N.; Altona, C. J. *Mol. Struct.* **1986**, *139*, 247-253. (c) Butcher, S. S.; Cohen, R. A.; Rounds, T. C. *J. Chem. Phys.* **1971**, *54*, 4123-4124.

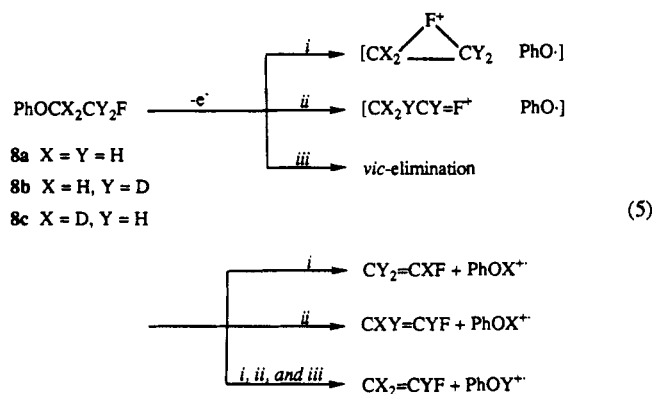

between the charged and neutral partners to yield phenol molecular ions and neutral fluoroethylene, as portrayed by the second step of eq 5. The  $^{19}\text{F}$  NMR spectra ( $^1\text{H}$ -decoupled) of the labeled fluoroethylenes from ionization of **8b** and **8c** in the electron bombardment flow (EBFlow) reactor are reproduced in Figure 2, and the proportions of the isotopomers of fluoroethylene are summarized in Table I.

Neutral product studies also give results consistent with fluorine transposition in free ions. Electron bombardment of a mixture of  $\text{BrCH}_2\text{CD}_2\text{F}$  and *tert*-butyl chloride in the EBFlow yields 1-chloro-1-fluoroethanes as the predominant products from the gaseous fluoroethyl cations. These recovered neutrals are produced by chloride abstraction from *tert*-butyl chloride (analogous to fluoride abstraction reactions previously reported from *tert*-butyl fluoride<sup>4,9</sup>), as eq 6 depicts. Both  $d_2$  isomers are recovered (in

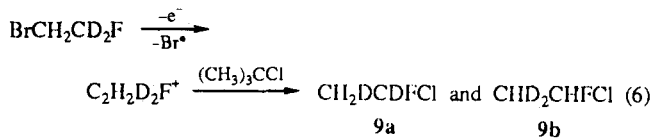

an approximate ratio of  $9\text{a}:9\text{b} = 2/1$ ). This means that if fluorine bridging takes place, the epifluoronium ion isomerizes via eq 1 (just like the ions discussed in ref 6) prior to its neutralization by chloride abstraction.

## Discussion

Gaseous molecular ions derived from **8** decompose via ion-neutral complexes, some of which contain epifluoronium ions (**1a**), which are deprotonated before they have a chance to rearrange to **2a**. The comparison summarized in eq 3 bears out one of the predictions for a complex-mediated mechanism: namely that radical cations and conjugate acid ions yield nearly the same ratios of  $\text{C}_2\text{H}_2\text{DF}$  versus  $\text{C}_2\text{HD}_2\text{F}$  expulsion. Since the proton affinities of phenoxy radical and phenol are close, this is consistent with the expectation that the observed branching ratios do not depend on whether the parent ion is an odd-electron or an even-electron species. The mass spectrometric data confirm our interpretation that the neutral products collected in the EBFlow reflect the fluoroethyl cations formed in the intermediate ion-neutral complexes. Field ionization-CAD studies have shown that the  $\text{C}_6\text{H}_6\text{O}^{+\cdot}$  fragment from the radical ion of **8c** has exclusively the structure phenol<sup>+</sup>.<sup>20</sup> It is likely that the  $\text{C}_6\text{H}_5\text{DO}^{+\cdot}$  fragment has the structure  $\text{PhOD}^{+\cdot}$  and that the corresponding fragments from **8b** also have exclusively phenolic structures.

The distribution of recovered neutral products in the EBFlow agrees well with the ratio of  $\text{PhOH}^{+\cdot}$  to  $\text{PhOD}^{+\cdot}$  observed in the electron impact mass spectra of **8b** and **8c**.<sup>16</sup> Three important features warrant emphasis: (1) A major product ( $\text{CHF}=\text{CD}_2$  from **8b**,  $\text{CDF}=\text{CH}_2$  from **8c**) results from transposition of fluorine. (2) A major product ( $\text{CDF}=\text{CHD}$  from **8b**,  $\text{CHF}=\text{CHD}$  from **8c**) results from transposition of hydrogen. (3) No product is observed in which hydrogen and fluorine have both

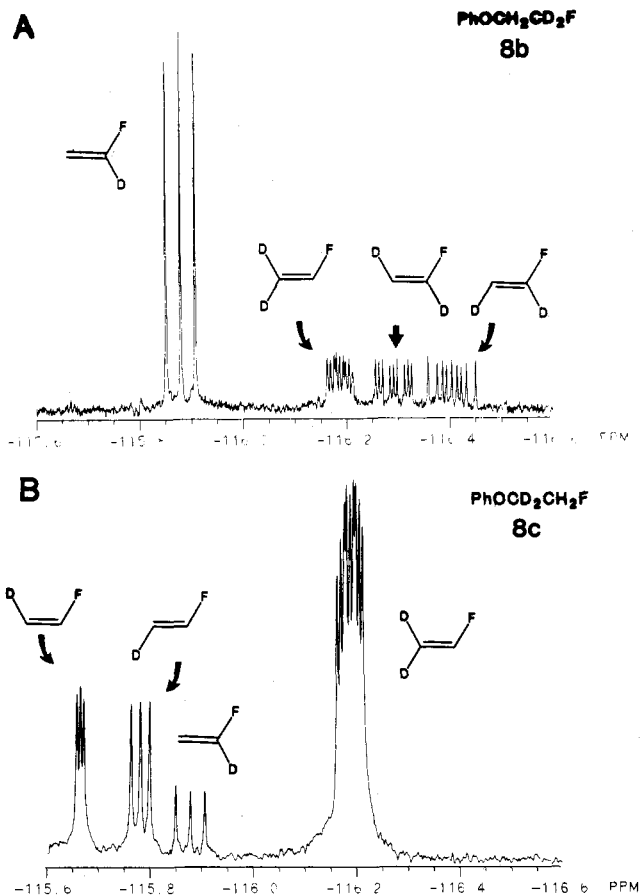
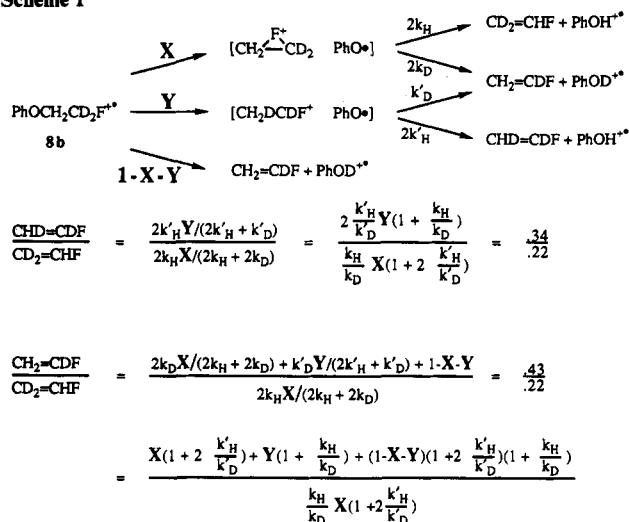

Figure 2. Proton-decoupled 470.4-MHz  $^{19}\text{F}$  NMR spectra of neutral fluoroethylenes from 70-eV electron bombardment of gaseous **8b** (A) and **8c** (B).

## Scheme I



transposed ( $\text{CHF}=\text{CHD}$  from **8b**,  $\text{CDF}=\text{CHD}$  from **8c**).

A simple calculation of branching ratios and isotope effects leads to the conclusion that, for the radical ions of **8**, the competition between pathways i and ii in eq 5 corresponds to the branching ratios  $\text{ii}/\text{i} = 1.2 \pm 0.2$  for **8b** and  $\text{ii}/\text{i} = 2.4 \pm 0.5$  for **8c**. This is based on an analysis of the data in Table I after correction for extraneous  $\text{CD}_2=\text{CHF}$  in the neutral product from **8c**. The proportions of neutral products from **8b** correspond to a  $\text{PhOD}^{+\cdot}/\text{PhOH}^{+\cdot}$  ratio within experimental error of the value seen in the mass spectrum (cf. eq 3a), and we analyze the product distribution as shown in Scheme I. However, the mixture of fluoroethylenes from **8c** corresponds to a  $\text{PhOH}^{+\cdot}$  yield approximately 2 times greater than what is seen in the mass spectrum. We attribute this to side reactions that yield vicinal elimination

(20) Borchers, F.; Levens, K.; Nibbering, N. M. M.; Theissing, C. B. *Org. Mass Spectrom.* 1977, 12, 746-750.

**Table I.** Proportions of Neutral Products Recovered from 70-eV EBFlow Radiolyses of Dideuterated Fluoroethyl Phenyl Ethers<sup>a</sup>

	CH <sub>2</sub> =CDF	CD <sub>2</sub> =CHF	Z-CDH=CDF	E-CDH=CDF	Z-CDH=CHF	E-CDH=CHF
PhOCH <sub>2</sub> CD <sub>2</sub> F ( <b>8b</b> )	0.43 (0.03)	0.22 (0.02)	0.17 (0.01)	0.17 (0.02)	<0.005	<0.005
PhOCD <sub>2</sub> CH <sub>2</sub> F ( <b>8c</b> )	0.08 (0.02)	0.66 (0.03)	<0.005	<0.005	0.13 (0.01)	0.13 (0.01)

<sup>a</sup> Values in parentheses represent standard deviations based on three independent experiments.

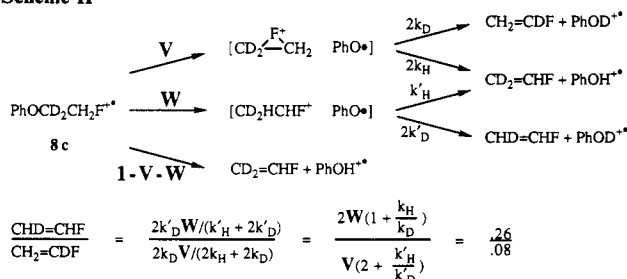
**Scheme II**

$$\frac{\text{CD}_2=\text{CHF}}{\text{CH}_2=\text{CDF}} = \frac{[2k_H V / (2k_H + 2k_D) + k'_H W / (k'_H + 2k'_D) + 1 \cdot V \cdot W]}{2k'_D V / (2k_H + 2k_D)} = \frac{.66}{.08}$$

$$= \frac{\frac{k_H}{k_D} V(2 + \frac{k'_H}{k'_D}) + \frac{k'_H}{k'_D} W(1 + \frac{k_H}{k_D}) + (1 - V \cdot W)(2 + \frac{k'_H}{k'_D})(1 + \frac{k_H}{k_D})}{V(2 + \frac{k'_H}{k'_D})}$$

but which do not produce PhOH<sup>+</sup>, and we correct the neutral product yield as summarized in Scheme II so that it agrees with the mass spectrometric measurement. Such vicinal elimination appears to play a much smaller role in **8b**, presumably because it is suppressed by a large primary deuterium isotope effect.

The data are analyzed in terms of Schemes I and II. There are two branching ratios and four deuterium isotope effects, but only four experimental product ratios (excluding the *E/Z* ratios, which equal 1.0 but are not germane) are available. We assume that the second step of pathway i has an isotope effect in the domain  $1.0 \leq k_H/k_D \leq 1.6$  (the range in which the values for all other proton transfers from unhindered carbocations have been found to lie<sup>7-9</sup>) and that the second step of pathway ii has a primary isotope effect,  $k'_H/k'_D$ , within the same domain (and a negligible secondary isotope effect). If we consider the mole fractions *X* and *Y* of pathways i and ii from **8b**<sup>+</sup>, respectively, and the corresponding mole fractions *V* and *W* from **8c**<sup>+</sup>, we arrive at the algebraic expressions shown in Schemes I and II. The values of *X* and *V* turn out to be functions of  $k_H/k_D$ , while the values of *Y* and *W* are functions of  $k'_H/k'_D$ .

From the experimental data and the assumed domains of  $k_H/k_D$  and  $k'_H/k'_D$ , we get a range of values for the mole fractions corresponding to each pathway. The values of  $W/V$  and  $(1 - W - V)/V$  are the branching ratios ii/i and iii/i for **8c**<sup>+</sup>, while the values of  $Y/X$  and  $(1 - X - Y)/X$  are the branching ratios for **8b**<sup>+</sup>. If we suppose that there must be a normal isotope effect on pathway iii (i.e. iii/i for **8b** not greater than iii/i for **8c**), this imposes further constraints on the allowable solutions for Schemes I and II (for instance, it does not permit the isotope effects to exceed the upper bound that we have imposed). We compute the proportions of the competing pathways to be  $40 \pm 4\%$  i,  $48 \pm 3\%$  ii, and  $9 \pm 5\%$  iii for **8b** and  $26.5 \pm 3\%$  i,  $63 \pm 6\%$  ii, and  $13.5 \pm 6\%$  iii for **8c**. (The percentages do not sum exactly to 100% because of the manner in which the uncertainties overlap.) The proportions for **8c**<sup>+</sup> are probably not much different from the values for the undeuterated analogue **8a**<sup>+</sup>, since this represents a competition among fluoride bridging, hydride shift, and vicinal elimination in which the secondary isotope effects may be comparable.

The experimental data imply that transposition of fluorine and hydrogen are competing and not sequential events. They rule out a transposition of fluorine in the molecular ion (which had been proposed elsewhere<sup>16</sup>) prior to the shift of hydrogen. If such an isomerization of **8**<sup>+</sup> had occurred, then we should have seen

products from a subsequent hydrogen shift, which would have corresponded to sequential F- and H-transposition. Because *no* products of sequential shift are observed, the molecular ions cannot be rearranging their labels while maintaining (or reverting to) covalent structures corresponding to **8**<sup>+</sup>. In our view, the results can be accommodated only by a mechanism that includes cleavage of the  $sp^3$ -carbon-oxygen bond with formation of bridged ion **1** (which had elsewhere been considered and rejected for the cases  $X = \text{Cl}$  and  $X = \text{Br}$ <sup>21</sup>). The proportions of path i versus path ii in **8b** show that deuteride shift is 1.2 times more probable than fluoride transposition. This is to be compared with results for the higher homologue  $\text{CH}_2\text{CDFCH}_2\text{OPh}^{+\bullet}$  (**3**<sup>+</sup>), for which deuteride shift is 4 times more likely than fluoride transposition.<sup>4</sup>

The occurrence of vicinal elimination (pathway iii) without any transposition invites comment. This is comparable to the proportion of vicinal elimination reported for **3**<sup>+</sup> ( $\approx 8\%$ ).<sup>4</sup> Because the partition among pathways i-iii must be nearly the same for  $\text{MD}^+$  ions as for  $\text{M}^{+\bullet}$  (since the EI and CI mass spectra show nearly the same proportions of  $\text{C}_2\text{H}_2\text{DF}$  and  $\text{C}_2\text{HD}_2\text{F}$  loss), vicinal elimination cannot be occurring via a dionic intermediate (which is a pathway unique to radical cations). An alternative possibility is for elimination without transposition to occur via a hydrogen-bonded complex that forms in competition with ion-neutral complexes. Such a possibility is consistent with a suggestion by Audier et al. in their interpretation of the MIKES of *sec*-alkyl phenyl ether molecular ions.<sup>22</sup> The corresponding intermediates from **8** might be represented as  $[\text{PhOH}^{+\bullet} \cdots \text{CH}_2=\text{CHF}]$  derived from **8a**<sup>+</sup> and  $[\text{PhOHD}^{+\bullet} \cdots \text{CH}_2=\text{CHF}]$  for the  $\text{MD}^+$  ion from **8a**. The species in brackets are intended to portray local minima on the potential energy surface and are not meant to imply that these possess static structures.

In principle, the ion-neutral complexes depicted in eq 5 could be transition states leading to hydrogen-bonded complexes. In the case of the next higher homologue, such an interpretation can be ruled out. The complexes derived from **3** (represented schematically in eq 2) interconvert via hydride shifts prior to expulsion of phenol<sup>+</sup>,<sup>4</sup> implying that they must have nonzero lifetimes. However, for the cations derived from **8**, the experimental evidence rules out interconversion of the complexes. On the one hand, this implies (strictly speaking) that pathway i either passes through a discrete intermediate (**1a** PhO<sup>+</sup>), as drawn in eq 5) or else corresponds to a transition state en route to structures that *cannot* subsequently decompose via **[2a PhO<sup>+</sup>]** (pathway ii). On the other hand, since free fluoroethyl cations assume the structure **2a**, as revealed by eq 6, we may confidently conclude that **1a** does indeed convert to **2a** on the microsecond time scale.<sup>6</sup> Species that decompose much faster than the **1a** → **2a** isomerization, such as ion-neutral complexes containing **1a**, ought nevertheless to have nonzero lifetimes. Otherwise we should have expected to recover the neutral fluoroethylenes that result from hydride shift subsequent to fluoride shift (which are conspicuously absent in the data reproduced in Figure 2).

**Conclusion**

The long-sought epifluoronium ion (**1a**) has been found to correspond to a stable structure. Neutral product studies of gaseous ion-neutral complexes show that fluorine transposition and hydrogen transposition in cationic precursors containing  $\text{FCH}_2\text{CH}_2$  groups are competing pathways. The absence of any products from sequential rearrangements suggests that the two pathways produce distinct, noninterconverting intermediates, which

(21) Theissling, C. B.; Nibbering, N. M. M.; De Boer, T. J. *Adv. Mass Spectrom.* **1971**, *5*, 642-650.

(22) Sozzi, G.; Audier, H. E.; Mourgues, P.; Milliet, A. *Org. Mass Spectrom.* **1987**, *22*, 746-747.

correspond to structures **1a** and **2a**, respectively.

Neutral product studies show that free fluoroethyl ions convert to the most stable structure (**2a**), as had previously been shown by collisional activation mass spectrometry.<sup>6</sup> In these ions, hydrogen and fluorine shifts occur one after the other. Regardless of the order in which these sequential transpositions occur, free ions that are formed and neutralized on the millisecond time scale isomerize to  $\alpha$ -fluoroethyl cations before they can be interrogated. On the other hand, over much shorter intervals, decompositions of ion-neutral complexes, which occur on the subnanosecond time scale, afford a glimpse of the antecedent rearrangements. The

implications of this are the subject of continuing investigations.

**Acknowledgment.** This work was supported by NSF Grants CHE 8802086 and CHE 9203066. We are grateful to Dr. Thomas Shaler and Dr. Dan Borchardt for experimental assistance and useful discussions.

**Supplementary Material Available:** A figure showing observed and simulated <sup>1</sup>H NMR spectra for **8a**, tabulated solutions for Schemes I and II, and tables of SCF-calculated geometries and normal modes for the structures in Figure 1 (16 pages). Ordering information is given on any current masthead page.

## Characterization of Iron-Sulfur Cubane Clusters by Fast Atom Bombardment Mass Spectrometry: The Formation of Ionic $[\text{Fe}_m\text{S}_n]$ Clusters through Gas-Phase Unimolecular Reduction Processes and Their Solution Parallels

Wen-Lian Lee,<sup>1a</sup> Douglas A. Gage,<sup>1b</sup> Zhi-Heng Huang,<sup>1b</sup> Chi K. Chang,<sup>\*1a</sup> Mercuri G. Kanatzidis,<sup>\*1a</sup> and John Allison<sup>\*1a</sup>

Contribution from the Departments of Chemistry and Biochemistry, Michigan State University, East Lansing, Michigan 48824. Received October 15, 1991

**Abstract:** Fast atom bombardment mass spectrometry (FAB-MS) has been used to analyze a series of iron-sulfur clusters  $(\text{A})_2\text{Fe}_4\text{S}_4\text{X}_4$ , where A = R<sub>4</sub>N or Ph<sub>4</sub>P and X = Cl, Br, SET, SPh. A cluster with mixed Cl, SPh ligands was also studied. The usefulness of the FAB technique in characterizing these and related biologically-relevant complexes is evaluated. The best FAB-MS results for these clusters were obtained with 3-nitrobenzyl alcohol (NBA) and 2-nitrophenyl octyl ether (NPOE) as matrices. The most unique feature of the negative ion FAB mass spectra is the identification of the intact ionic core  $[\text{Fe}_4\text{S}_4\text{X}_4]^-$ , preformed anions  $[(\text{A})\text{Fe}_4\text{S}_4\text{X}_4]^-$ , and a series of cluster fragment ions. A mechanism is proposed to explain the formation of small  $[\text{Fe}_m\text{S}_n]$  clusters through unimolecular reduction processes that involve only +2 and +3 oxidation states for the Fe atoms. This work demonstrates that FAB-MS can be employed as a valid method for rapid molecular weight determination as well as structural elucidation of  $[\text{Fe}_4\text{S}_4]$  cluster-containing complexes.

### Introduction

Proteins containing iron-sulfur clusters frequently serve as redox enzymes and participate in electron-transfer reactions associated with processes such as photosynthesis, nitrite reduction, and nitrogen fixation.<sup>2,3</sup> At present, four distinct types of Fe-S cluster cores, in various oxidation states, have been identified in such enzymes: FeS<sub>4</sub>, Fe<sub>2</sub>S<sub>2</sub>, Fe<sub>3</sub>S<sub>4</sub>, and Fe<sub>4</sub>S<sub>4</sub>. The iron centers in these clusters form bridges in proteins, usually by bonding to sulfur atoms of cysteine residues. Most of these clusters participate in one-electron redox processes.<sup>4</sup> They frequently contain iron atoms in one or more oxidation states, usually Fe<sup>3+</sup> and Fe<sup>2+</sup>. A variety of iron/sulfur core oxidation states have been established for the various Fe/S clusters present in proteins. Those identified to date include the following:  $[\text{Fe}_2\text{S}_2]^{1+,2+}$ ,  $[\text{Fe}_3\text{S}_4]^{0,1+}$ , and  $[\text{Fe}_4\text{S}_4]^{1+,2+,3+}$ .

In view of the diversity of structures and biological functions, these complexes are difficult to characterize by direct studies of the proteins themselves. Fortunately, synthetic analogs of the mono-, bi-, and tetrairon centers have been developed to provide insights into their intrinsic properties in the absence of protein-imposed constraints. Of the structurally characterized synthetic

models for the various  $[\text{Fe}_m\text{S}_n]$  clusters now available, the cubane-type,  $[\text{Fe}_4\text{S}_4]$ , core geometry appears to be the most commonly encountered, and it has been the focus of an intensive body of structural, spectroscopic, and magnetic studies for the last two decades.<sup>5,6</sup> A wide variety of model complexes of the type  $[\text{Fe}_4\text{S}_4\text{X}_4]^{2-}$  have been made in which the anionic components, X<sup>-</sup>, are a variety of thiolates (SR<sup>-</sup>),<sup>6</sup> halides (Cl<sup>-</sup>, Br<sup>-</sup>, and I<sup>-</sup>),<sup>7,8</sup> and alkoxides (OR<sup>-</sup>),<sup>9</sup> as well as combinations of these ligands.<sup>10</sup>

(5) (a) Holm, R. H. *Acc. Chem. Res.* **1977**, *10*, 427. (b) Berg, J. M.; Holm, R. H. In *Iron-Sulfur Proteins*; Spiro, T. G., Ed.; Wiley-Interscience: New York, 1982; p 1.

(6) Averill, B. A. In *Metal Clusters in Proteins*. Que, L., Jr., Ed. *ACS Symp. Ser.* **1988**, No. 372, 258.

(7) (a) Hagen, K. S.; Reynolds, J. G.; Holm, R. H. *J. Am. Chem. Soc.* **1981**, *103*, 4054. (b) Hagen, K. S.; Holm, R. H. *J. Am. Chem. Soc.* **1982**, *104*, 5496. (c) Hagen, K. S.; Watson, A. D.; Holm, R. H. *J. Am. Chem. Soc.* **1983**, *105*, 3905. (d) Wong, G. B.; Bobrik, M. A.; Holm, R. H. *Inorg. Chem.* **1978**, *17*, 578. (e) Johnson, R. W.; Holm, R. H. *J. Am. Chem. Soc.* **1978**, *100*, 5338.

(8) (a) Coucouvanis, D.; Kanatzidis, M.; Simhon, E.; Baenziger, D. C. *J. Am. Chem. Soc.* **1982**, *104*, 1874. (b) Kanatzidis, M. G.; Salifoglou, A.; Coucouvanis, D. *Inorg. Chem.* **1986**, *25*, 2460.

(9) Cleland, W. E., Jr.; Holtman, D. A.; Sabat, M.; Ibers, J. A.; Defotis, G. C.; Averill, B. A. *J. Am. Chem. Soc.* **1983**, *105*, 6021. (b) Cleland, W. E., Jr.; Averill, B. A. *Inorg. Chim. Acta* **1985**, *106*, L17.

(10) (a) Kanatzidis, M. G.; Ryan, M.; Coucouvanis, D.; Simopoulos, A.; Kostikas, A. *Inorg. Chem.* **1983**, *22*, 179. (b) Johnson, R. E.; Papaefthymiou, G. C.; Frankel, R. B.; Holm, R. H. *J. Am. Chem. Soc.* **1983**, *105*, 7280. (c) Kanatzidis, M. G.; Baenziger, N. C.; Coucouvanis, D.; Simopoulos, A.; Kostikas, A. *J. Am. Chem. Soc.* **1984**, *106*, 4500. (d) Kanatzidis, M. G.; Coucouvanis, D.; Simopoulos, A.; Kostikas, A.; Papaefthymiou, V. *J. Am. Chem. Soc.* **1985**, *107*, 4925.

(1) (a) Department of Chemistry. (b) Department of Biochemistry.

(2) Thauer, R. K.; Schoenheit, P. In *Iron-Sulfur Proteins*; Spiro, T. G., Ed.; Wiley Interscience: New York, 1982; p 329.

(3) Thompson, A. J. In *Metalloproteins*; Harrison, P., Ed.; Verlag Chemie: Weinheim, FRG, 1985; Part I, p 79.

(4) (a) Carter, C. W.; Kraut, J.; Freer, S. T.; Alden, R. A.; Sieker, L. C.; Adman, E.; Jensen, L. H. *Proc. Natl. Acad. Sci. U.S.A.* **1972**, *68*, 3526. (b) Herskovitz, T.; Averill, B. A.; Holm, R. H.; Ibers, J. A.; Phillips, W. D.; Weiher, J. F. *Proc. Natl. Acad. Sci. U.S.A.* **1972**, *69*, 2437.